

**R-3329/R-2559**

**US 74 Monroe Bypass**

**Permit Impact Drawings**

09/08/99

TIP PROJECT: R-3329 / R-2559

CONTRACT: C202587

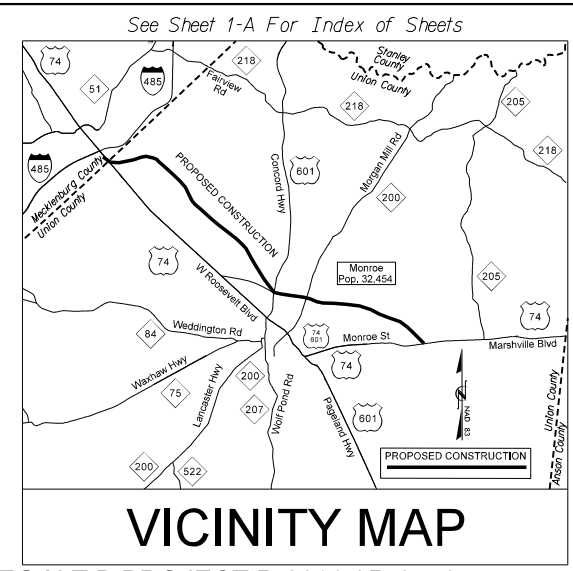

STATE OF NORTH CAROLINA  
DIVISION OF HIGHWAYS

# MECKLENBURG & UNION COUNTY

LOCATION: US 74 BYPASS FROM US 74 JUST EAST OF I-485 NEAR MATTHEWS AND STALLINGS TO US 74 JUST EAST OF WINGATE AND WEST OF MARSHVILLE

TYPE OF WORK: DESIGN-BUILD WETLAND AND STREAM IMPACTS

STATE	STATE PROJECT REFERENCE NO.	SHEET NO.	TOTAL SHEETS
N.C.	R-3329 /R-2559	1	
STATE PROJ. NO.	F.A. PROJ. NO.	DESCRIPTION	
34533.5.TA1			

PERMIT DRAWING  
SHEET 1 OF 267

INCOMPLETE PLANS  
DO NOT USE FOR R/W ACQUISITION

PRELIMINARY PLANS  
DO NOT USE FOR CONSTRUCTION

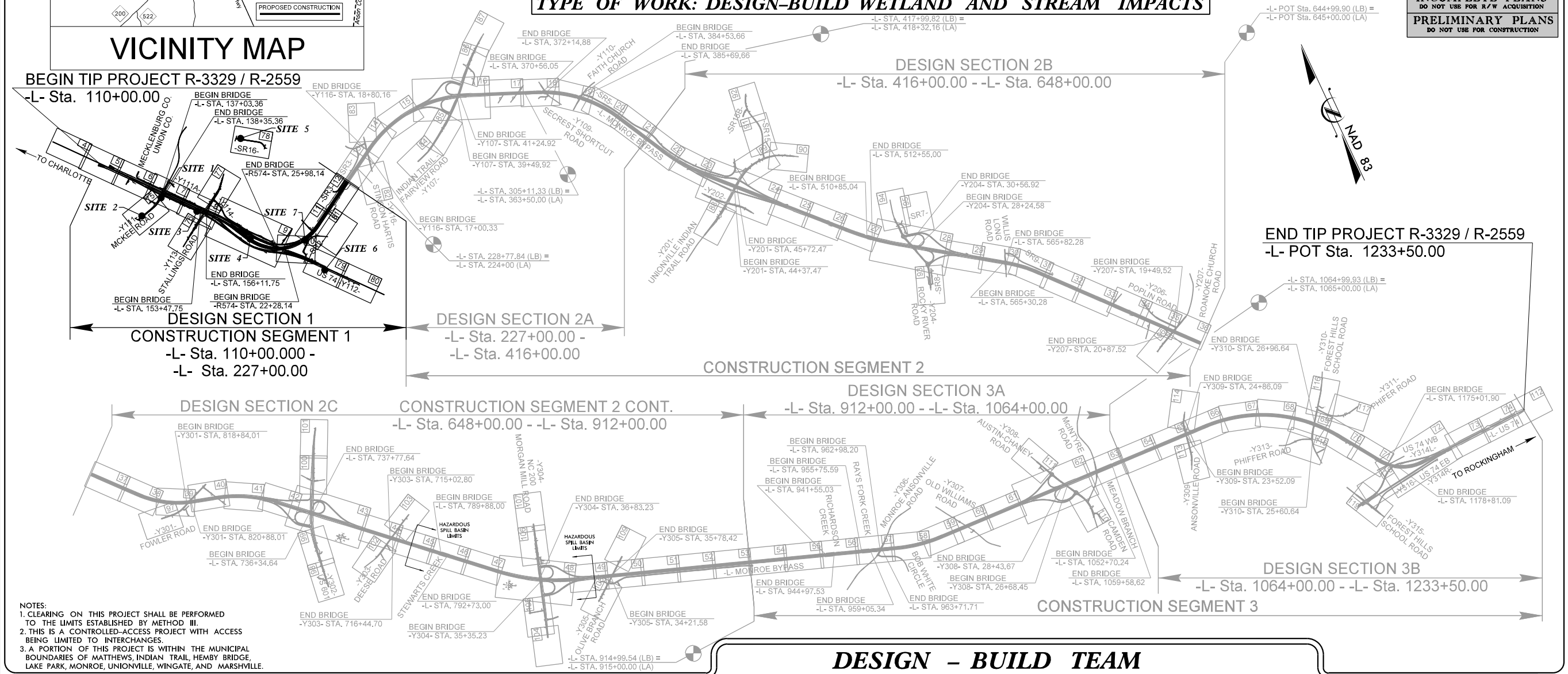

- NOTES:
- CLEARING ON THIS PROJECT SHALL BE PERFORMED TO THE LIMITS ESTABLISHED BY METHOD III.
  - THIS IS A CONTROLLED-ACCESS PROJECT WITH ACCESS BEING LIMITED TO INTERCHANGES.
  - A PORTION OF THIS PROJECT IS WITHIN THE MUNICIPAL BOUNDARIES OF MATTHEWS, INDIAN TRAIL, HEMBY BRIDGE, LAKE PARK, MONROE, UNIONVILLE, WINGATE, AND MARSHVILLE.

## DESIGN - BUILD TEAM

PLANS PREPARED BY :



RUMMEL, KLEPPER & KAHL, LLP  
900 RIDGEFIELD DRIVE, SUITE 350  
RALEIGH, NORTH CAROLINA 27609  
NC LICENSE NO. F-012

2012 STANDARD SPECIFICATIONS

LETTING DATE:  
OCTOBER 28, 2010

J.T. Peacock, Jr., P.E.  
PROJECT ENGINEER

Stephen E. Roberts, P.E.  
PROJECT DESIGN ENGINEER

CONTRACTOR :



HYDRAULICS ENGINEER

SIGNATURE: \_\_\_\_\_  
ROADWAY DESIGN ENGINEER

SIGNATURE: \_\_\_\_\_  
P.E.

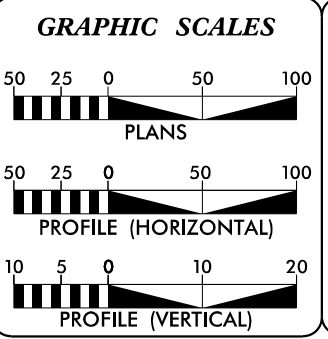

DESIGN DATA

ADT 2013 =	64,100
ADT 2035 =	95,600
DHV =	8%
D =	55%
T =	18%*
V =	70 mph
*TTST 11% DUAL 7% FUNCTIONAL CLASS.: FREEWAY	

PROJECT LENGTH

LENGTH ROADWAY TIP PROJECT R-3329 /R-2559.....	18.1 mi
LENGTH STRUCTURE TIP PROJECT R-3329 /R-2559.....	*1.6 mi
TOTAL LENGTH TIP PROJECT R-3329 /R-2559.....	19.7 mi

\* LENGTH OF STRUCTURES BASED ON WB LANES

9/29/2014 R:\Hydraulics\PERMITS\_Env\ironment\al\Drawings\Section\N3329\_R2559\_HYD\_PRM\_WET\_sect1\_tshn.dgn Fkeys

8/17/99 R:\Drawings\PERMITS\Environmental\Drawings\HYD\_PRM\_DitchDet\_Sec01.dgn R:\Hydraulics\PERMITS\Environmental\Drawings\Section1\R3329\_R2559\_HYD\_PRM\_DitchDet\_Sec01.dgn



PROJECT REFERENCE NO.	SHEET NO.
R-3329 / R-2559	1-2N
RW SHEET NO.	
ROADWAY DESIGN ENGINEER	HYDRAULICS ENGINEER
<b>INCOMPLETE PLANS</b> DO NOT USE FOR A/W ACQUISITION	
<b>PRELIMINARY PLANS</b> DO NOT USE FOR CONSTRUCTION	
<b>PERMIT DRAWING</b>	
<b>SHEET 2 OF 267</b>	

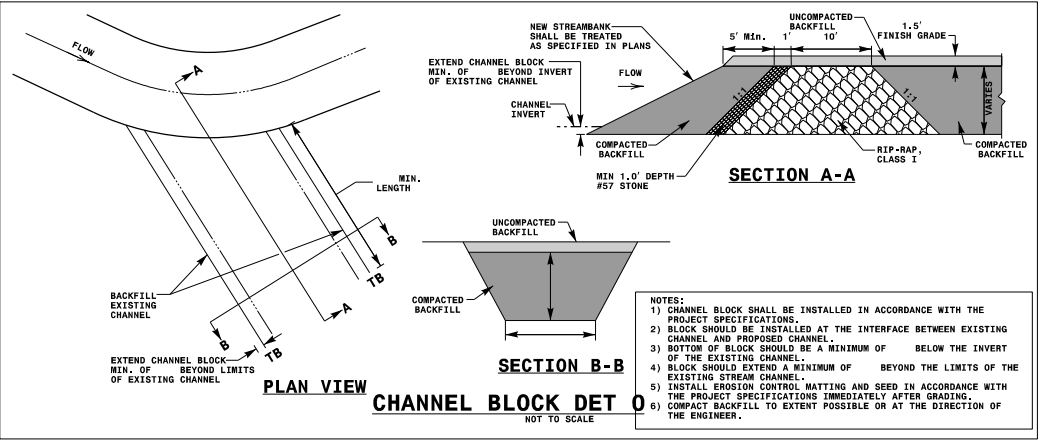
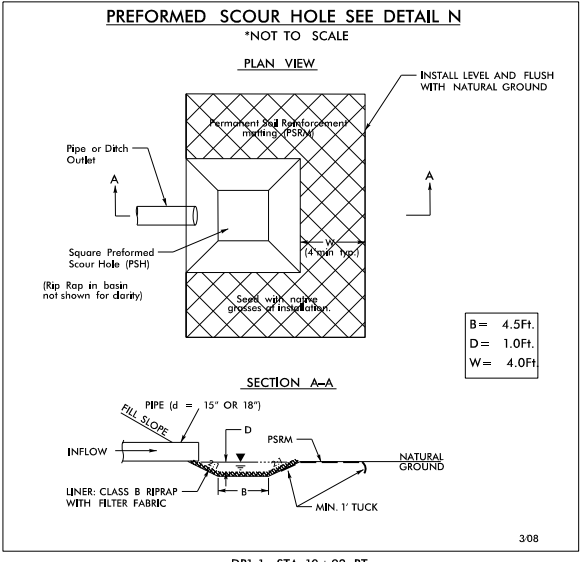
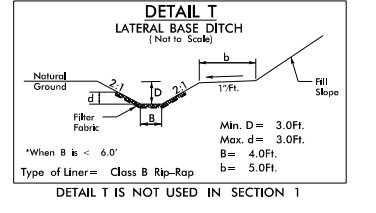
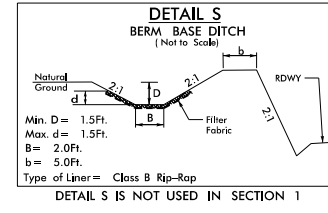
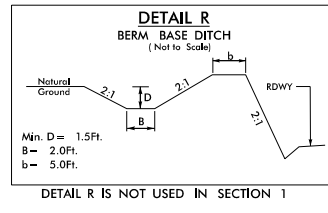
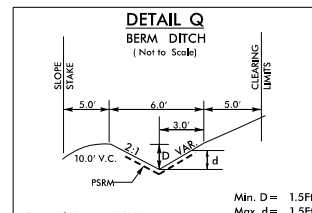
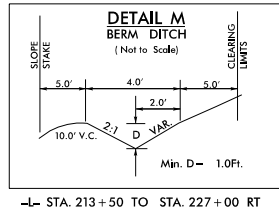
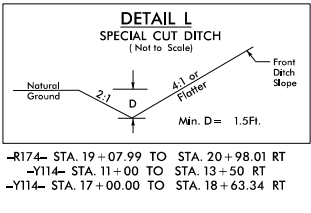
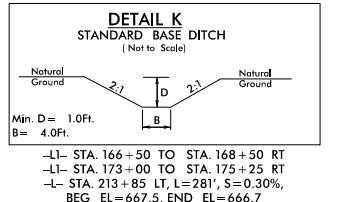
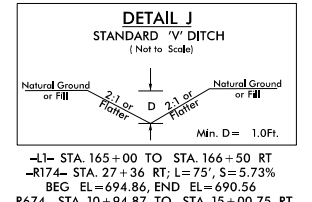
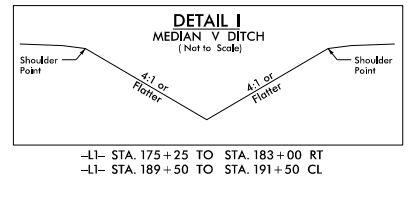
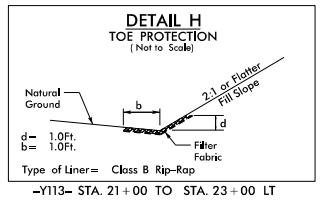
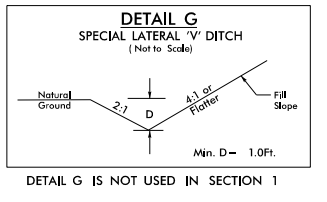
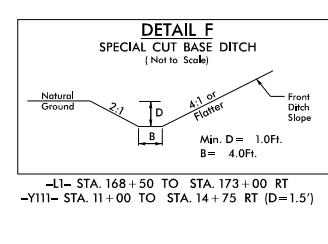
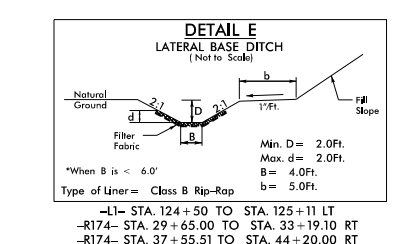
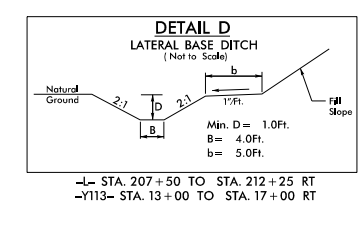
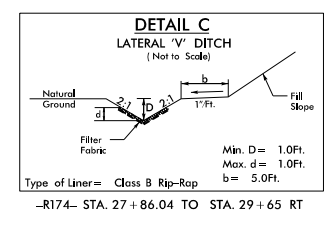
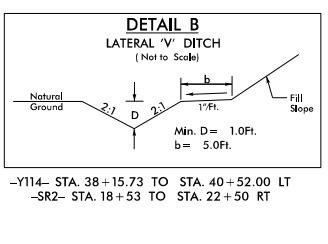
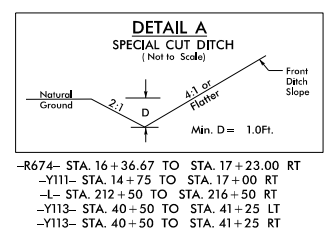

Ditch Grade	L	Ditch Grade	L
0.0% To 2.0%	20'	Over 4.0% To 6.0%	40'
Over 2.0% To 4.0%	30'	Over 6.0%	50'

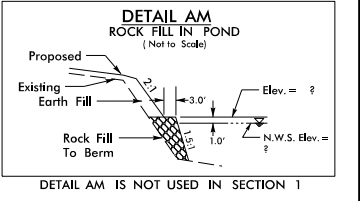
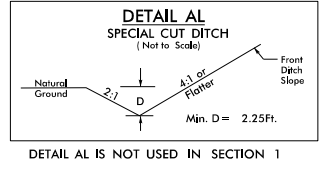
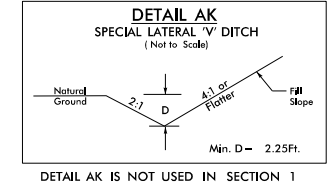
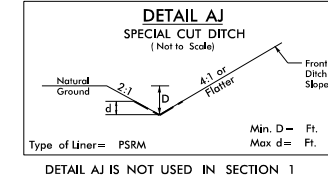
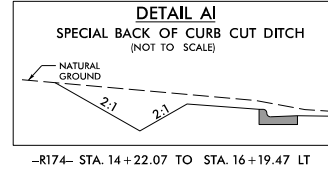
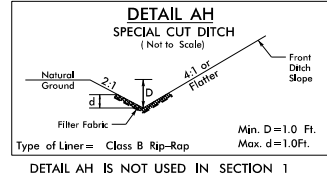
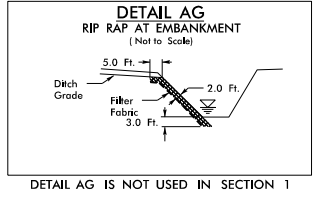
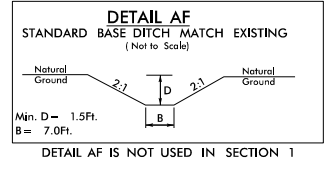
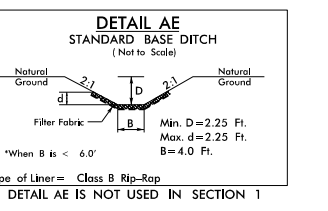
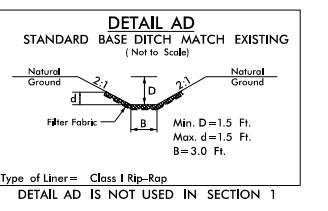
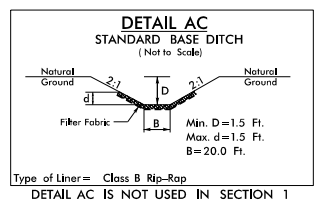
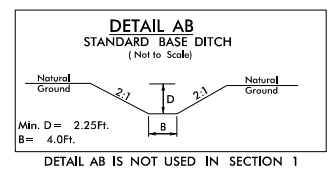
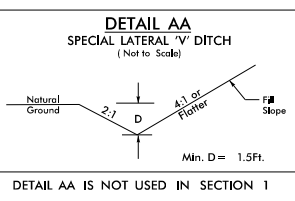
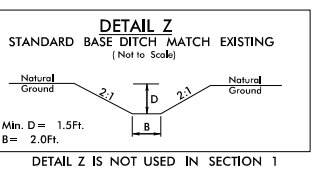
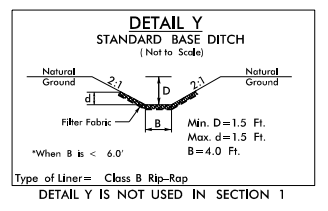
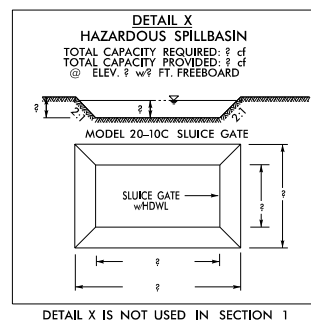
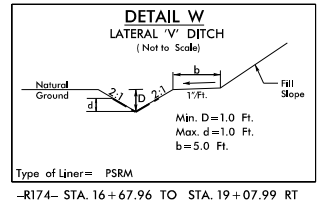
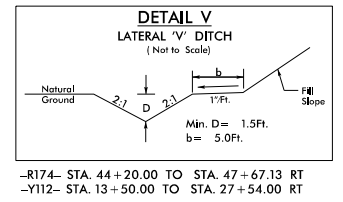
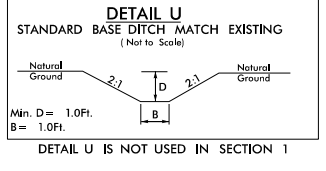



PROJECT REFERENCE NO. R-3329 / R-2559	SHEET NO. 1-20
RW SHEET NO.	
ROADWAY DESIGN ENGINEER	HYDRAULICS ENGINEER
<b>INCOMPLETE PLANS</b> DO NOT USE FOR A/W ACQUISITION <b>PRELIMINARY PLANS</b> DO NOT USE FOR CONSTRUCTION <b>PERMIT DRAWING</b> <b>SHEET 3 OF 267</b>	

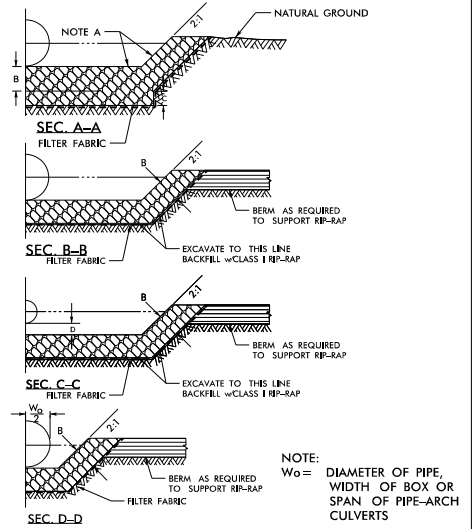
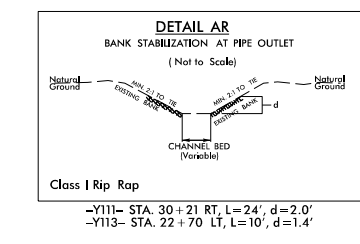
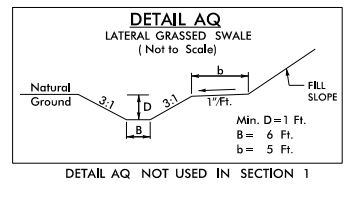
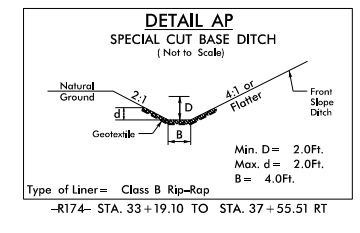
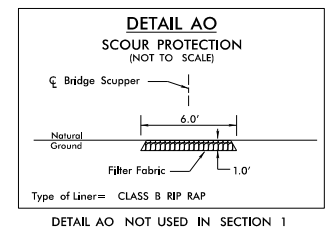
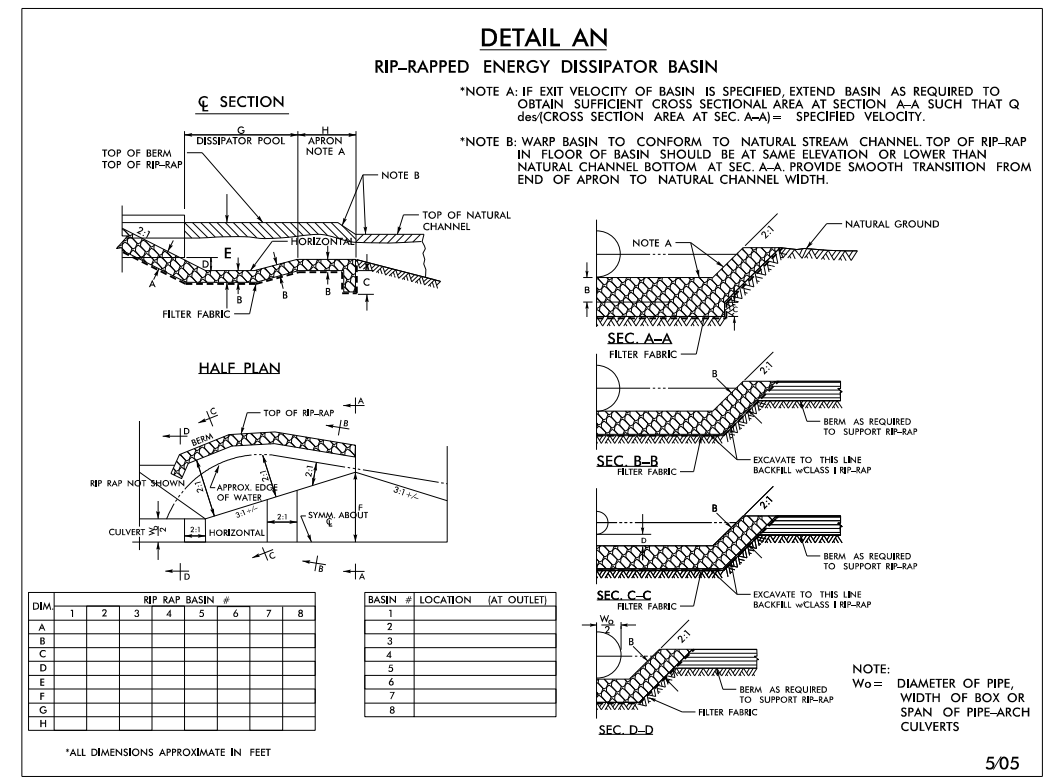

505

NORTH FORK CROOKED CREEK TRIB. 5  
-DR\_1- STA. 11+55

NORTH FORK CROOKED CREEK TRIB. 5  
-Y111- STA. 21+41

NORTH FORK CROOKED CREEK TRIB. 4  
-R174- STA. 29+69

NORTH FORK CROOKED CREEK TRIB. 4  
-L- STA. 175+72

NORTH FORK CROOKED CREEK TRIB. 5  
-L- STA. 140+01

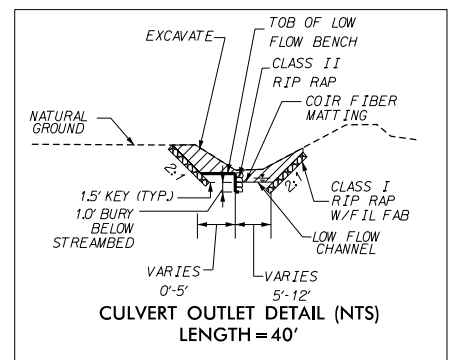
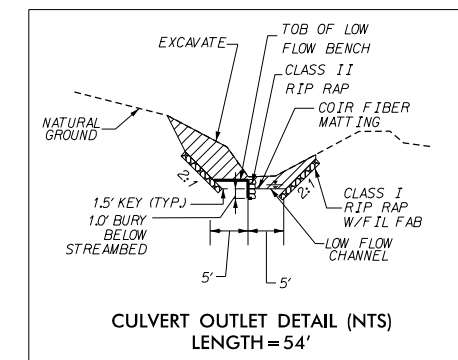
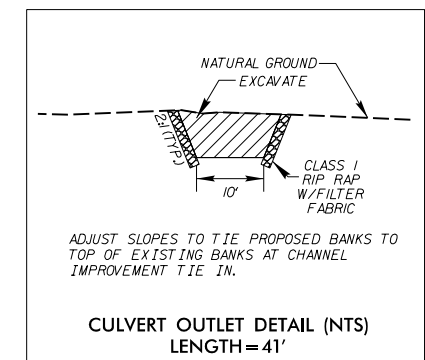
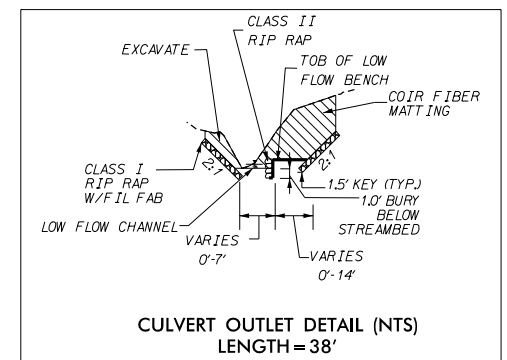
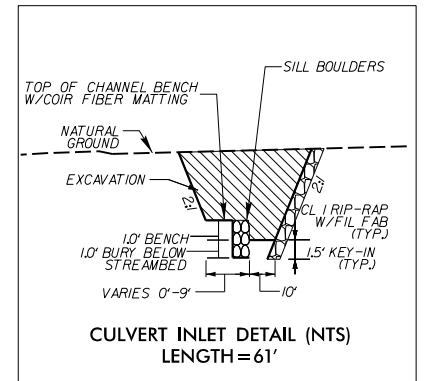
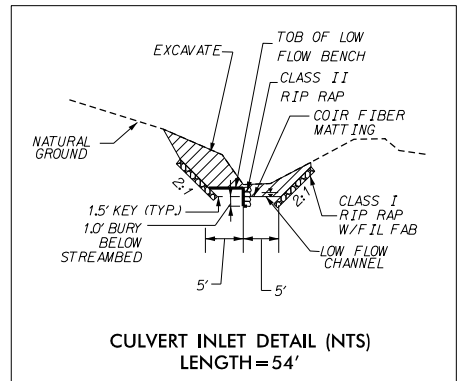
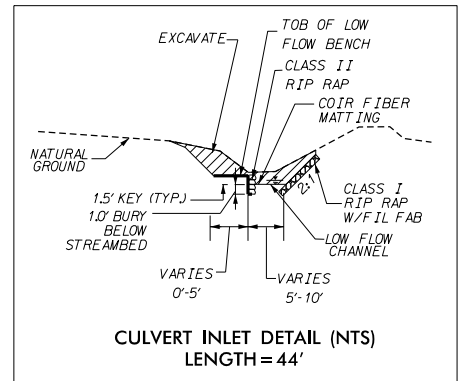
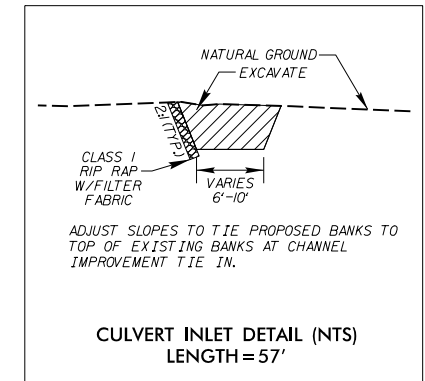
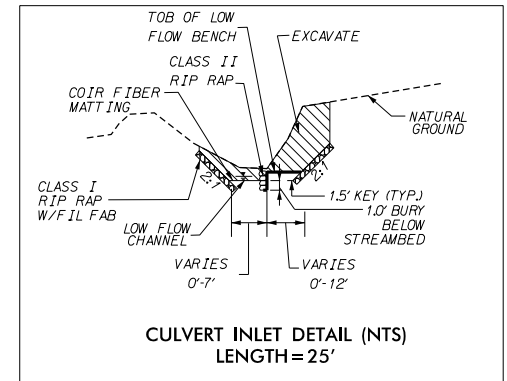

8/17/99

R:\Hudraulics\PERMITS\Environmental\Drawings\Section1\R3329\_R2559\_HYD\_PRM\_DitchDet\_Sec01.dgn



8/17/99  
R:\Hurd\ulics\PERMITS\Environmental\Drawings\Section1\R3329\_R2559\_HYD\_PRM\_WET\_PSH007.dgn  
8/30/2014

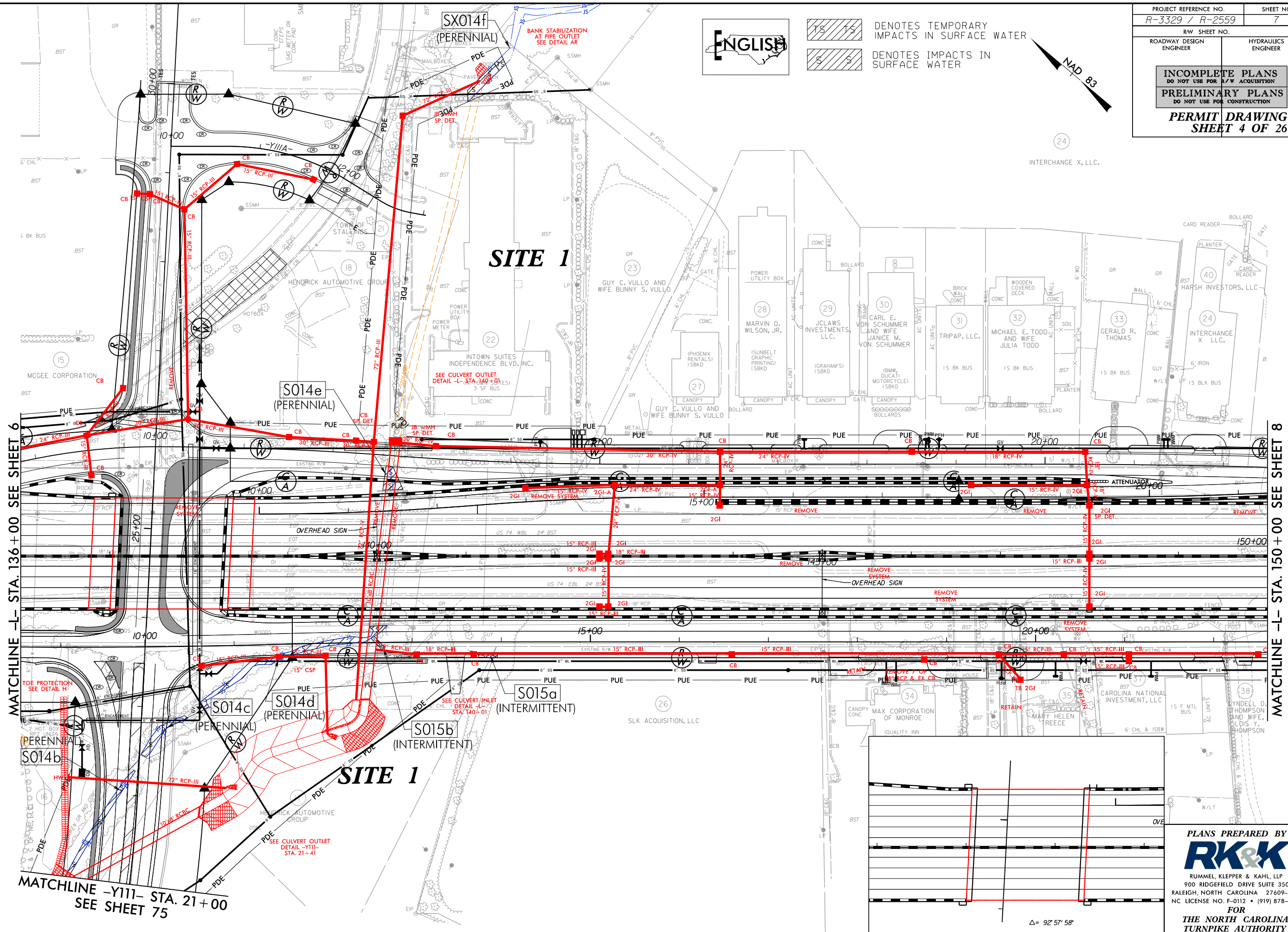

PROJECT REFERENCE NO. R-3329 / R-2559	SHEET NO. 7
RW SHEET NO.	
ROADWAY DESIGN ENGINEER	HYDRAULICS ENGINEER
INCOMPLETE PLANS DO NOT USE FOR A/W ACQUISITION	
PRELIMINARY PLANS DO NOT USE FOR CONSTRUCTION	
PERMIT DRAWING SHEET 4 OF 267	

PLANS PREPARED BY :  
**RK&K**  
RUMMEL, KLEPPER & KAHL, LLP  
900 RIDGEFIELD DRIVE SUITE 350  
RALEIGH, NORTH CAROLINA 27609-3960  
NC LICENSE NO. F-0112 • (919) 878-9560  
FOR  
THE NORTH CAROLINA  
TURNPIKE AUTHORITY

Δ = 92° 57' 58"



8/17/99  
R:\Hudson\lics\PERMITS\Environmental\Drawings\Section1\R3329\_R2559\_HYD\_PRM\_WET\_PSH007\_con.dgn  
8/30/2014

PROJECT REFERENCE NO. R-3329 / R-2559	SHEET NO. 7
RW SHEET NO.	
ROADWAY DESIGN ENGINEER	HYDRAULICS ENGINEER
INCOMPLETE PLANS DO NOT USE FOR A/W ACQUISITION	
PRELIMINARY PLANS DO NOT USE FOR CONSTRUCTION	
PERMIT DRAWING SHEET 5 OF 267	

**ENGLISH**

TS TS DENOTES TEMPORARY IMPACTS IN SURFACE WATER

S S DENOTES IMPACTS IN SURFACE WATER

NAD 83

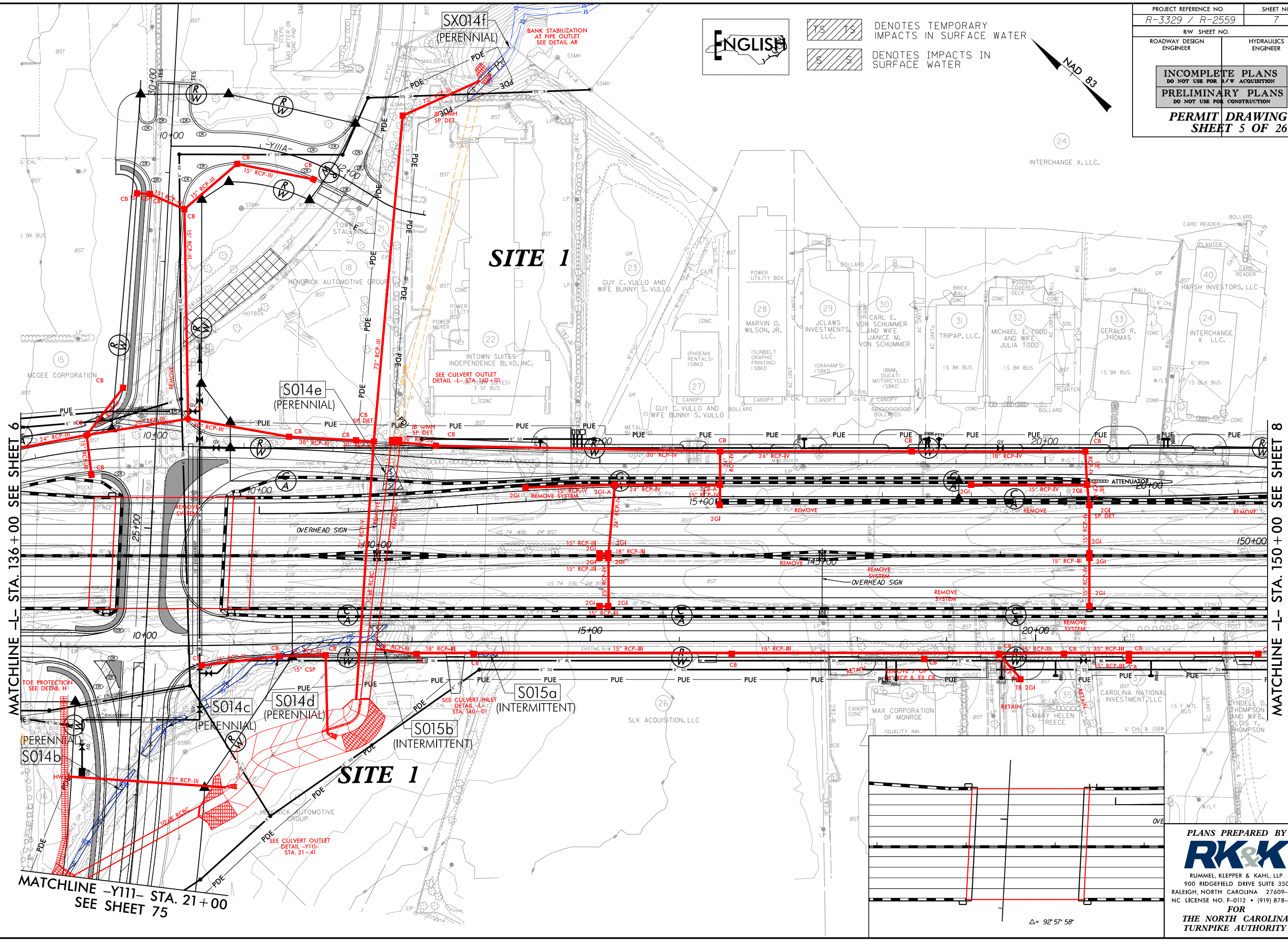

MATCHLINE -L- STA. 136+00 SEE SHEET 6

MATCHLINE -L- STA. 150+00 SEE SHEET 8





MATCHLINE -Y111- STA. 21+00  
SEE SHEET 75

PLANS PREPARED BY :  
**RK&K**  
RUMMEL, KLEPPER & KAHL, LLP  
900 RIDGEFIELD DRIVE SUITE 350  
RALEIGH, NORTH CAROLINA 27609-3960  
NC LICENSE NO. F-0112 • (919) 878-9560  
FOR  
THE NORTH CAROLINA  
TURNPIKE AUTHORITY

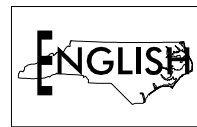
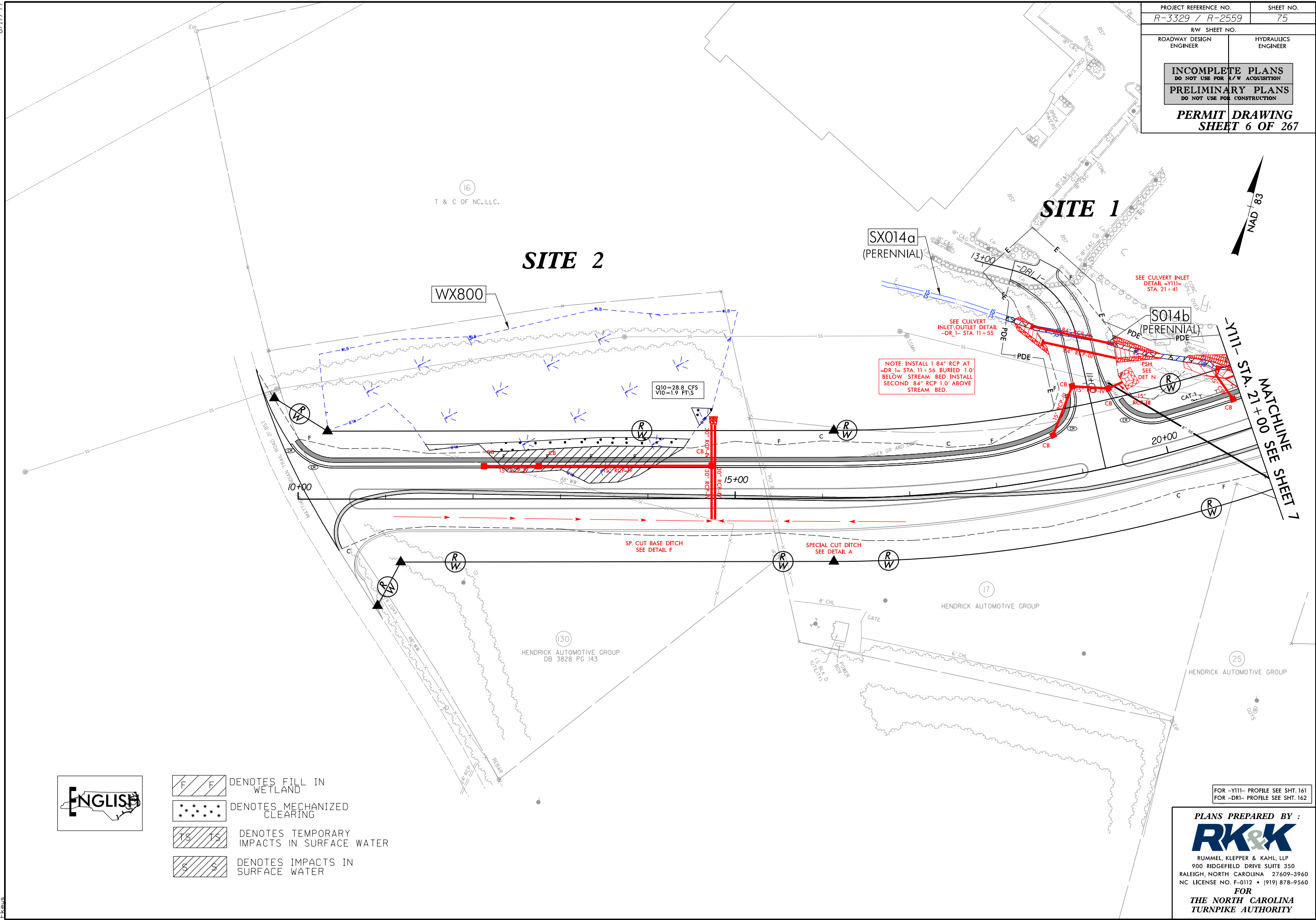
PROJECT REFERENCE NO. R-3329 / R-2559	SHEET NO. 75
RW SHEET NO.	
ROADWAY DESIGN ENGINEER	HYDRAULICS ENGINEER
<b>INCOMPLETE PLANS</b> DO NOT USE FOR A/W ACQUISITION <b>PRELIMINARY PLANS</b> DO NOT USE FOR CONSTRUCTION	
<b>PERMIT DRAWING</b> <b>SHEET 6 OF 267</b>	

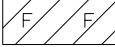
8/17/99  
 R:\Hydro\bu\lics\PERMITS\_Environmental\Drawings\Section1\R3329\_R2559\_HYD\_PRM\_WET\_PSH075.dgn  
 8/30/2014



-  DENOTES FILL IN WETLAND
-  DENOTES MECHANIZED CLEARING
-  DENOTES TEMPORARY IMPACTS IN SURFACE WATER
-  DENOTES IMPACTS IN SURFACE WATER

FOR -Y111- PROFILE SEE SHT. 161  
 FOR -DR1- PROFILE SEE SHT. 162

**PLANS PREPARED BY :**  
  
 RUMMEL, KLEPPER & KAHL, LLP  
 900 RIDGEFIELD DRIVE SUITE 350  
 RALEIGH, NORTH CAROLINA 27609-3960  
 NC LICENSE NO. F-0112 • (919) 878-9560  
 FOR  
**THE NORTH CAROLINA**  
**TURNPIKE AUTHORITY**





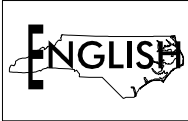
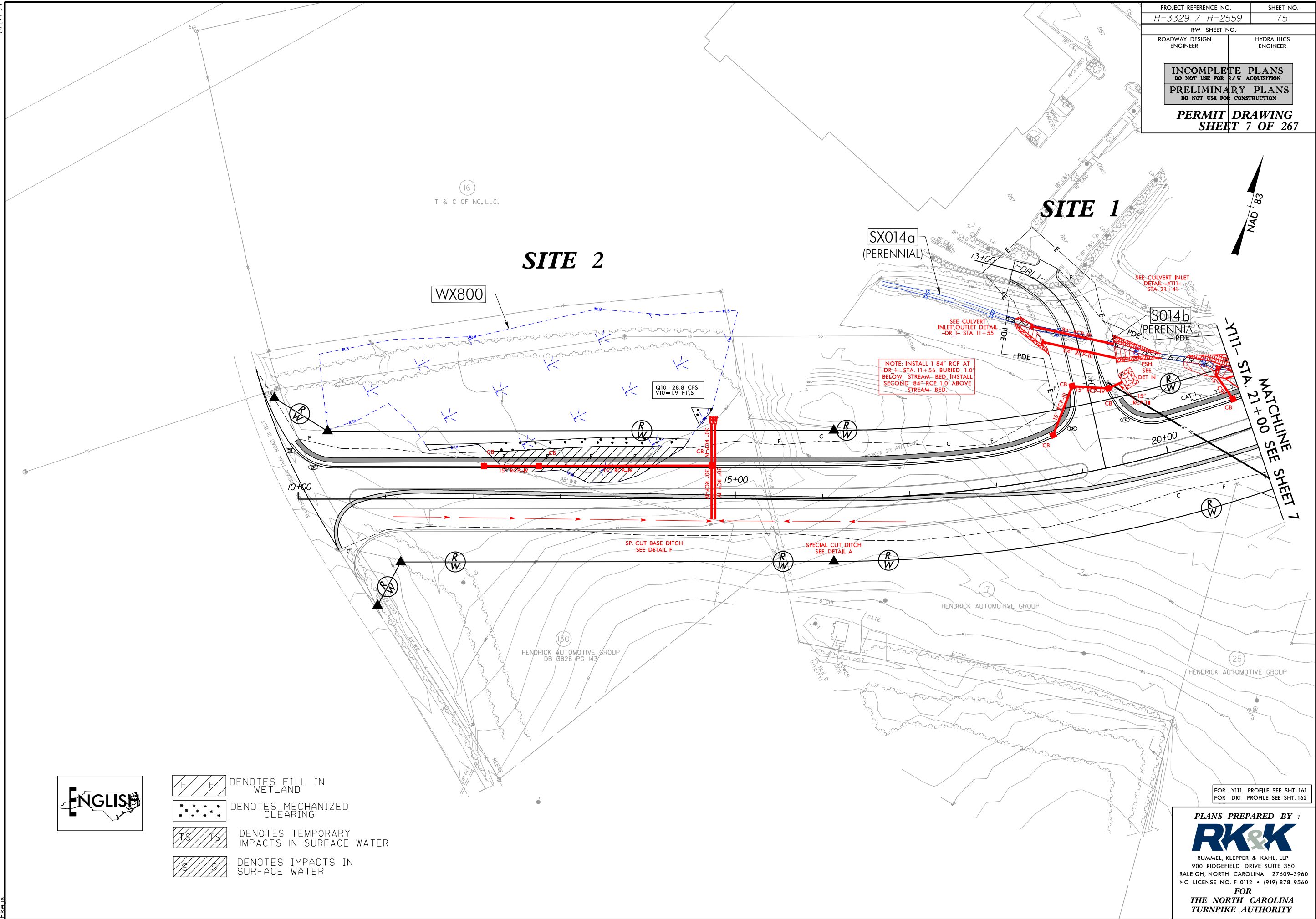

PROJECT REFERENCE NO. R-3329 / R-2559	SHEET NO. 75
RW SHEET NO.	
ROADWAY DESIGN ENGINEER	HYDRAULICS ENGINEER
<b>INCOMPLETE PLANS</b> DO NOT USE FOR A/W ACQUISITION <b>PRELIMINARY PLANS</b> DO NOT USE FOR CONSTRUCTION	
<b>PERMIT DRAWING</b> <b>SHEET 7 OF 267</b>	

8/17/99

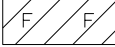
R:\Hydro\lics\PERMITS\_Environmental\Drawings\Section1\R3329\_R2559\_HYD\_PRM\_WET\_PSH075.con.dgn



-  DENOTES FILL IN WETLAND
-  DENOTES MECHANIZED CLEARING
-  DENOTES TEMPORARY IMPACTS IN SURFACE WATER
-  DENOTES IMPACTS IN SURFACE WATER

FOR -Y111- PROFILE SEE SHT. 161  
FOR -DRI- PROFILE SEE SHT. 162

**PLANS PREPARED BY :**  
  
 RUMMEL, KLEPPER & KAHL, LLP  
 900 RIDGEFIELD DRIVE SUITE 350  
 RALEIGH, NORTH CAROLINA 27609-3960  
 NC LICENSE NO. F-0112 • (919) 878-9560  
**FOR**  
**THE NORTH CAROLINA**  
**TURNPIKE AUTHORITY**



8/17/99  
 R:\30\2014\PERMITS\Environmental\Drawings\Section1\R3329\_R2559\_HYD\_PRM\_WET\_PSH008B.dgn



DENOTES TEMPORARY IMPACTS IN SURFACE WATER  
 DENOTES IMPACTS IN SURFACE WATER

PROJECT REFERENCE NO. R-3329 / R-2559	SHEET NO. 8
RW SHEET NO.	
ROADWAY DESIGN ENGINEER	HYDRAULICS ENGINEER
INCOMPLETE PLANS DO NOT USE FOR A/W ACQUISITION PRELIMINARY PLANS DO NOT USE FOR CONSTRUCTION	
PERMIT DRAWING SHEET 15 OF 267	

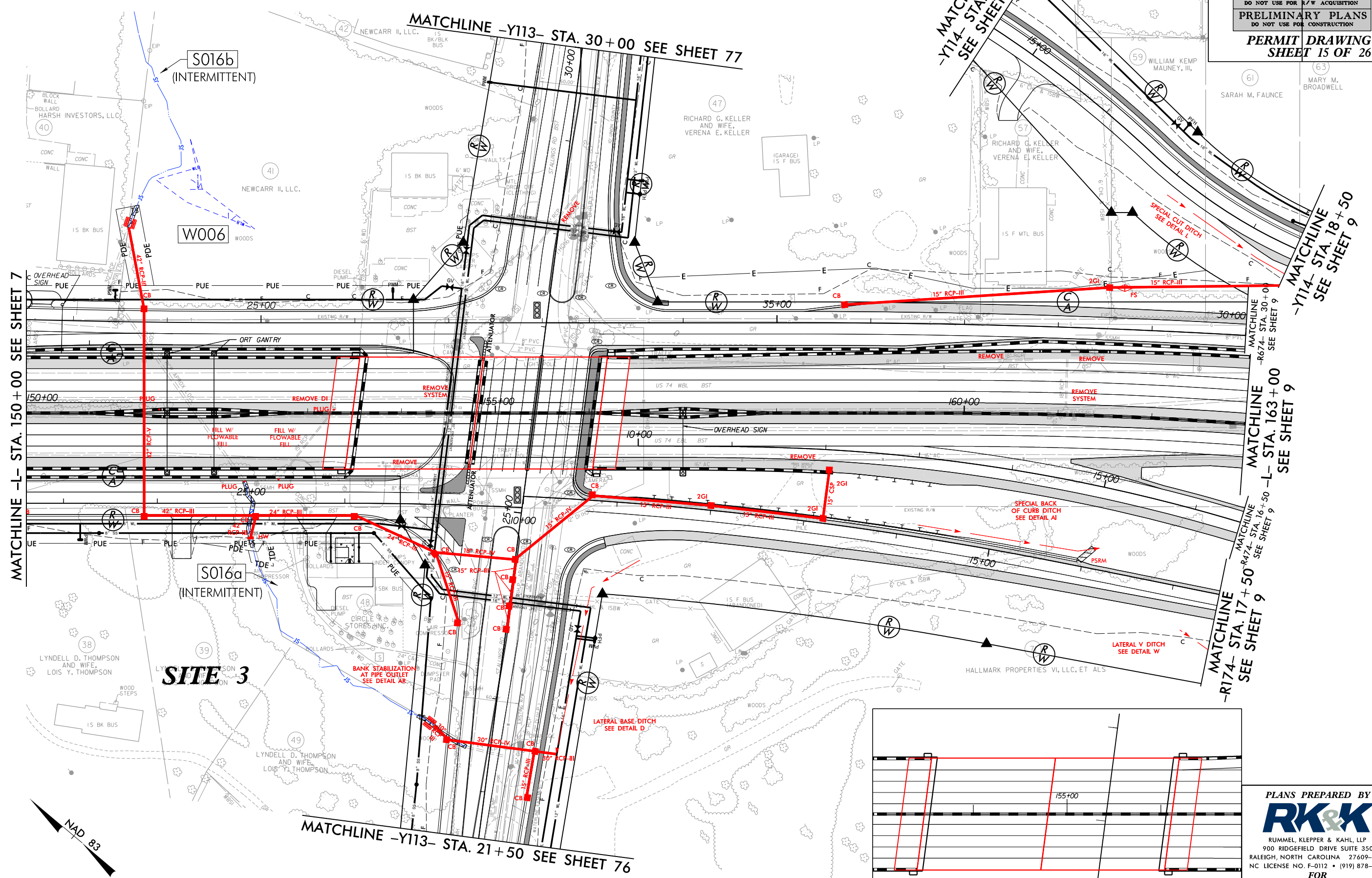

MATCHLINE -L- STA. 150 + 00 SEE SHEET 7

MATCHLINE -Y113- STA. 30 + 00 SEE SHEET 77

MATCHLINE -Y114- STA. 14 + 50 SEE SHEET 77

MATCHLINE -Y114- STA. 18 + 50 SEE SHEET 9

MATCHLINE -R674- STA. 30 + 00 SEE SHEET 9

MATCHLINE -R674- STA. 16 + 50 -L- STA. 163 + 00 SEE SHEET 9

MATCHLINE -R174- STA. 17 + 50 SEE SHEET 9

MATCHLINE -Y113- STA. 21 + 50 SEE SHEET 76

**SITE 3**

S016b (INTERMITTENT)

S016a (INTERMITTENT)

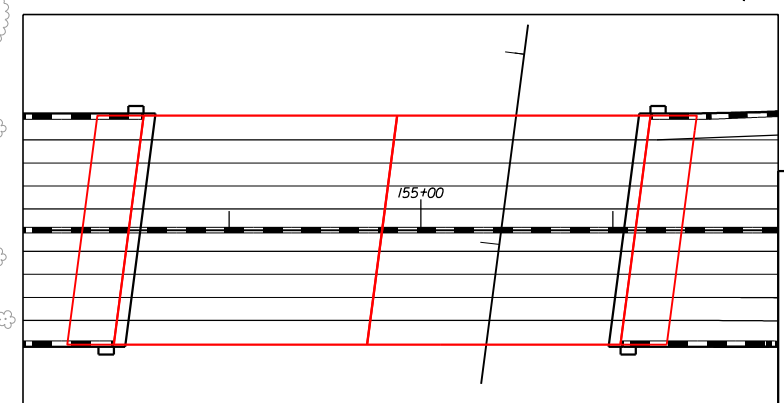
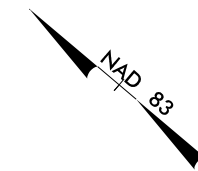

PLANS PREPARED BY :  
**RK&K**  
 RUMMEL, KLEPPER & KAHL, LLP  
 900 RIDGEFIELD DRIVE SUITE 350  
 RALEIGH, NORTH CAROLINA 27609-3960  
 NC LICENSE NO. F-0112 • (919) 878-9560  
 FOR  
 THE NORTH CAROLINA  
 TURNPIKE AUTHORITY



8/17/99  
R:\Hurd\bu\lics\PERMITS\Environmental\Drawings\Section1\R3329\_R2559\_HYD\_PRM\_WET\_PSH008\_con.dgn

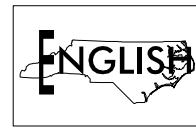

TS TS DENOTES TEMPORARY IMPACTS IN SURFACE WATER  
S S DENOTES IMPACTS IN SURFACE WATER

PROJECT REFERENCE NO. R-3329 / R-2559	SHEET NO. 8
RW SHEET NO.	HYDRAULICS ENGINEER
ROADWAY DESIGN ENGINEER	
INCOMPLETE PLANS DO NOT USE FOR A/W ACQUISITION	
PRELIMINARY PLANS DO NOT USE FOR CONSTRUCTION	
PERMIT DRAWING SHEET 16 OF 267	

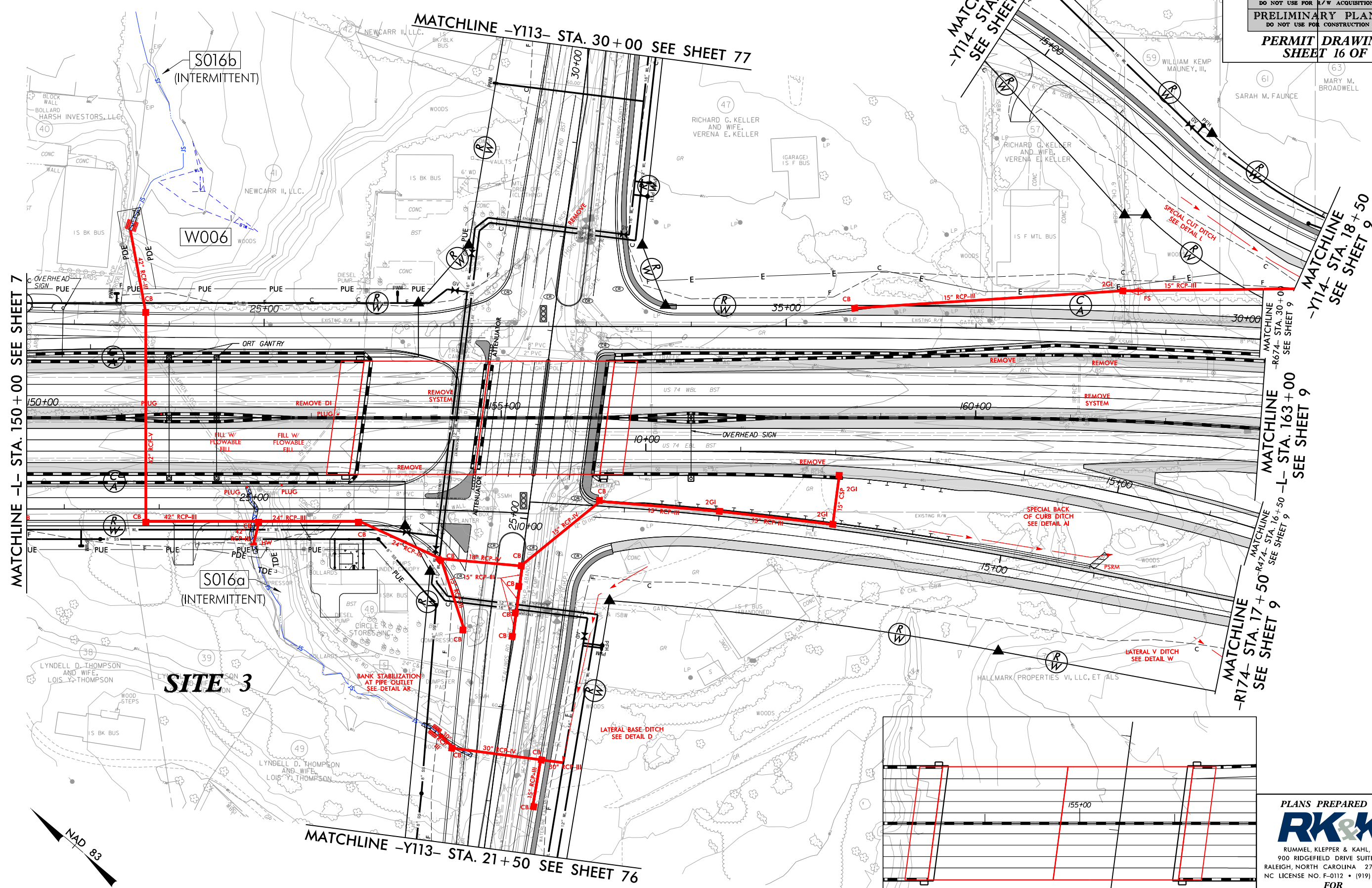

MATCHLINE -L- STA. 150 + 00 SEE SHEET 7

MATCHLINE -Y113- STA. 30 + 00 SEE SHEET 77

MATCHLINE -Y114- STA. 14 + 50 SEE SHEET 77

MATCHLINE -Y114- STA. 18 + 50 SEE SHEET 9

MATCHLINE -R674- STA. 30 + 00 SEE SHEET 9

MATCHLINE -L- STA. 163 + 00 SEE SHEET 9

MATCHLINE -R174- STA. 17 + 50 SEE SHEET 9

MATCHLINE -R474- STA. 16 + 50 SEE SHEET 9



MATCHLINE -Y113- STA. 21 + 50 SEE SHEET 76

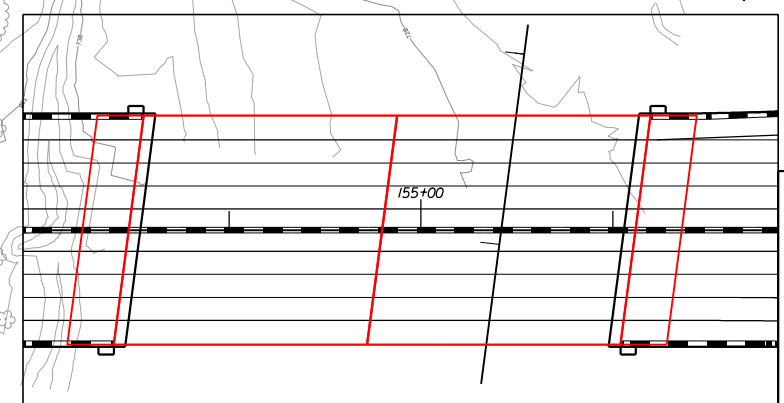

PLANS PREPARED BY :  
**RK&K**  
RUMMEL, KLEPPER & KAHL, LLP  
900 RIDGEFIELD DRIVE SUITE 350  
RALEIGH, NORTH CAROLINA 27609-3960  
NC LICENSE NO. F-0112 • (919) 878-9560  
FOR  
THE NORTH CAROLINA  
TURNPIKE AUTHORITY